

KITCHEN BAKER'S RACK ASSEMBLY INSTRUCTION

ITEM NO.: KB010101

Kitchen Baker's Rack

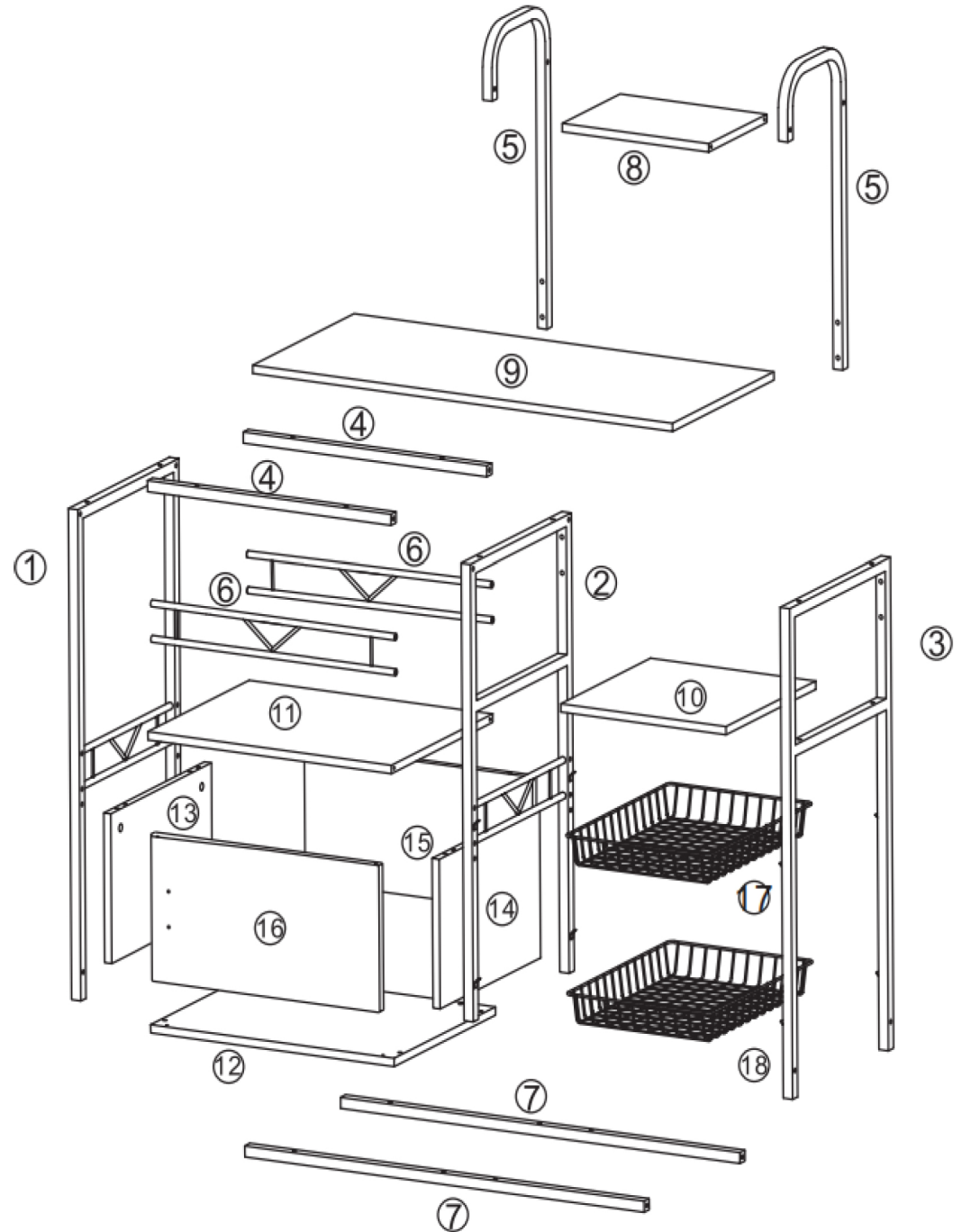
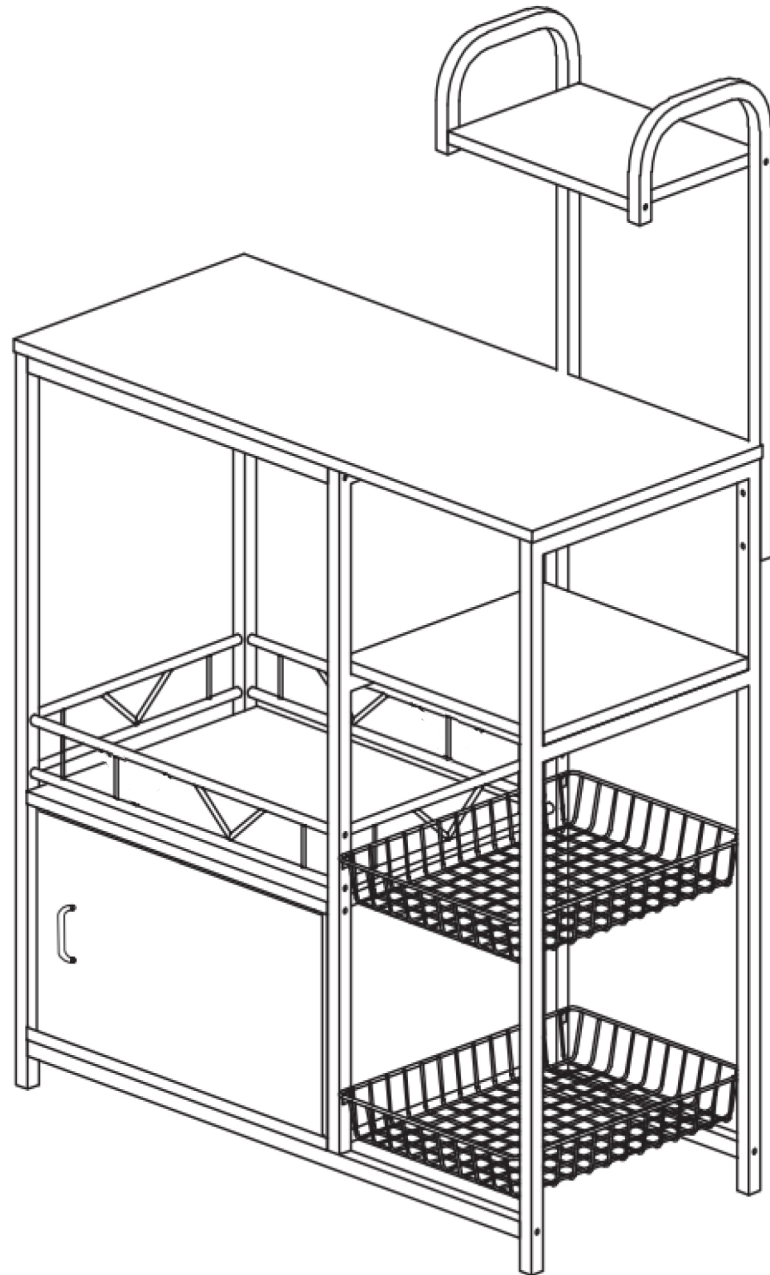

KITCHEN BAKER'S RACK ASSEMBLY INSTRUCTION

ITEM NO.: KB010101

Thank you for purchasing our Kitchen Baker's Rack. Be sure to check all packing material carefully for small parts that may have come loose inside the carton during shipment.

PRE-ASSEMBLY

- (1) Proper assembly of this item requires 2 people.
- (2) Do not dispose of any contents until assembly is completed to avoid accidentally discarding small parts or hardware.
- (3) Remove all parts and hardware from box and lay out on a carpeted or scratch-free work surface, such as the cardboard, as this will avoid damaging any parts during assembly.
- (4) Do not fully tighten all bolts until all parts are in place. Failure to follow these instructions may cause the bolts to misalign during assembly.

CARE INSTRUCTIONS

- (1) Hardware may loosen overtime. Periodically check that all connections are tight.
- (2) Wipe with a soft, dry cloth. To protect finish, avoid the use of chemicals and household cleaners.
- (3) All hot serving dishes should be placed on a pad.
- (4) Any liquid spilled onto the furniture should be cleaned up immediately with a damp cloth.

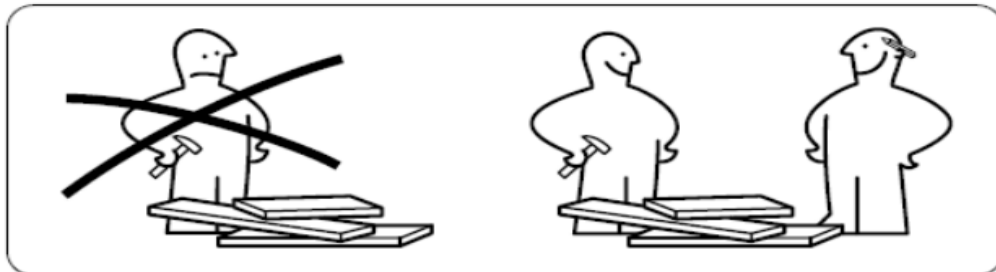

Proper assembly of this item requires 2 people

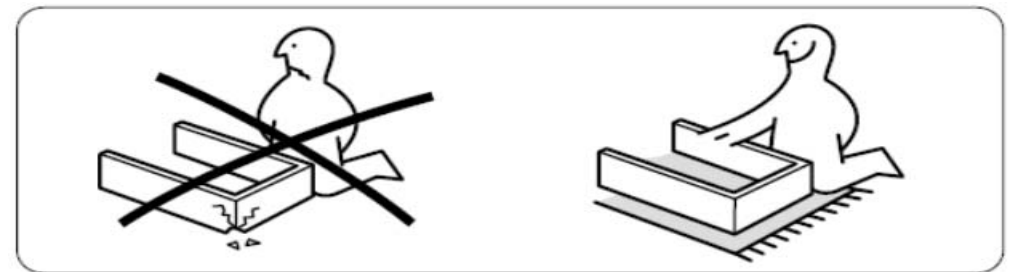









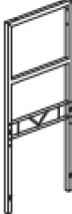



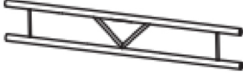

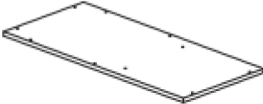

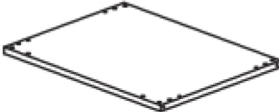
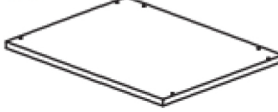
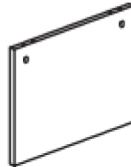
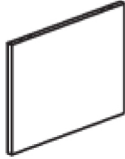
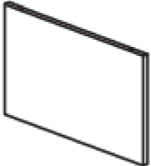

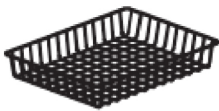
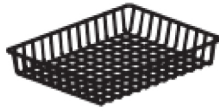





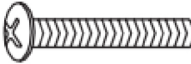

When assembling, please place it on a clean and smooth floor, such as carpet or cardboard.

KITCHEN BAKER'S RACK ASSEMBLY INSTRUCTION

ITEM NO.: KB010101

Parts & Hardware

<p>①</p>  <p>Left Side Frame 1PC</p>	<p>②</p>  <p>Side Frame 1PC</p>	<p>③</p>  <p>Right Side Frame 1PC</p>	<p>④</p>  <p>Top Crossbar 2PCS</p>	<p>⑤</p>  <p>Support Bar 2PCS</p>	<p>⑥</p>  <p>Mesh Grid 2PCS</p>	<p>⑦</p>  <p>Bottom Crossbar 2PCS</p>
<p>⑧</p>  <p>Top Rack 1PC</p>	<p>⑨</p>  <p>Top Panel 1PC</p>	<p>⑩</p>  <p>Shelf Panel 1PC</p>	<p>⑪</p>  <p>Cabinet Top Panel 1PC</p>	<p>⑫</p>  <p>Cabinet Bottom Panel 1PC</p>	<p>⑬</p>  <p>Cabinet Left Panel 1PC</p>	<p>⑭</p>  <p>Cabinet Right Panel 1PC</p>
<p>⑮</p>  <p>Cabinet Back Panel 1PC</p>	<p>⑯</p>  <p>Door Panel 1PC</p>	<p>⑰</p>  <p>Top Basket 1PC</p>	<p>⑱</p>  <p>Bottom Basket 1PC</p>	<p>A</p>  <p>Allen Key 1PC</p>	<p>B</p>  <p>Shelf Pin 2PCS</p>	<p>C</p>  <p>Dowel(ϕ6x30) 4PCS</p>
<p>D</p>  <p>Cam Bolt 6PCS</p>	<p>E</p>  <p>Cam Lock 6PCS</p>	<p>F</p>  <p>Long Sharp Bolt (St5x45) 8PCS</p>	<p>G</p>  <p>Door Knob 1PC</p>	<p>H</p>  <p>Small Bolt(M4x15) 2PCS</p>	<p>I</p>  <p>Long Bolt(M6x45) 4PCS</p>	<p>J</p>  <p>Nut 4PCS</p>
<p>K</p>  <p>Bolt(M6x27) 16PCS</p>	<p>L</p>  <p>Medium Bolt(M6x40) 18PCS</p>	<p>M</p>  <p>Flat Washer 1PC</p>	<p>N</p>  <p>Magnetic Latch 1PC</p>	<p>O</p>  <p>Mending Plate 1PC</p>	<p>P</p>  <p>Small Sharp Bolt (ST3X12) 4PCS</p>	<p>Q</p>  <p>Sharp Bolt(ϕ5x40) 6PCS</p>

KITCHEN BAKER'S RACK ASSEMBLY INSTRUCTION

ITEM NO.: KB010101

Step 1: Please assemble this kitchen baker's rack onto a clean and smooth surface such as carpet or cardboard. Insert six Cam Bolts(D) and four Dowels(C) into Cabinet Top Panel(11) as shown, make sure all Cam Bolts(D) and Dowels(C) are tightened and perpendicular to the panels. Fasten Magnetic Latch(N) to Cabinet Top Panel(11) by inserting two Small Sharp Bolts(P) and tighten with supplied Allen Key(A).

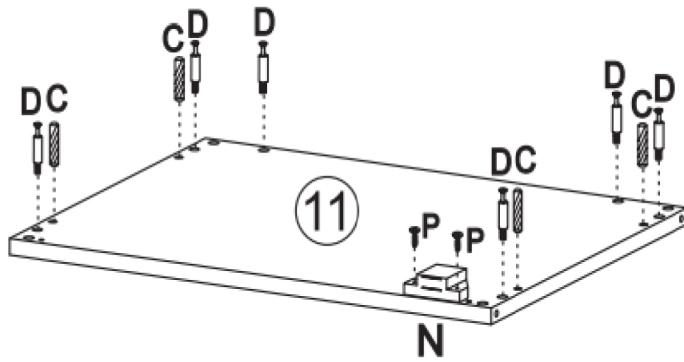

- C x4
- D x6
- P x2

Step 2: Attach Cabinet Left Panel(13), Cabinet Right Panel(14) and Cabinet Back Panel(15) to Cabinet Top Panel(11) as shown, please make sure six Cam Bolts(D) and four Dowel(C) on Cabinet Top Panel(11) are inserted into three panels(13,14,15). Then insert six Cam Locks(E) into three panels(13,14,15), turn Cam Locks(E) 1/2 turn (180 degrees) with Screwdriver to tighten.

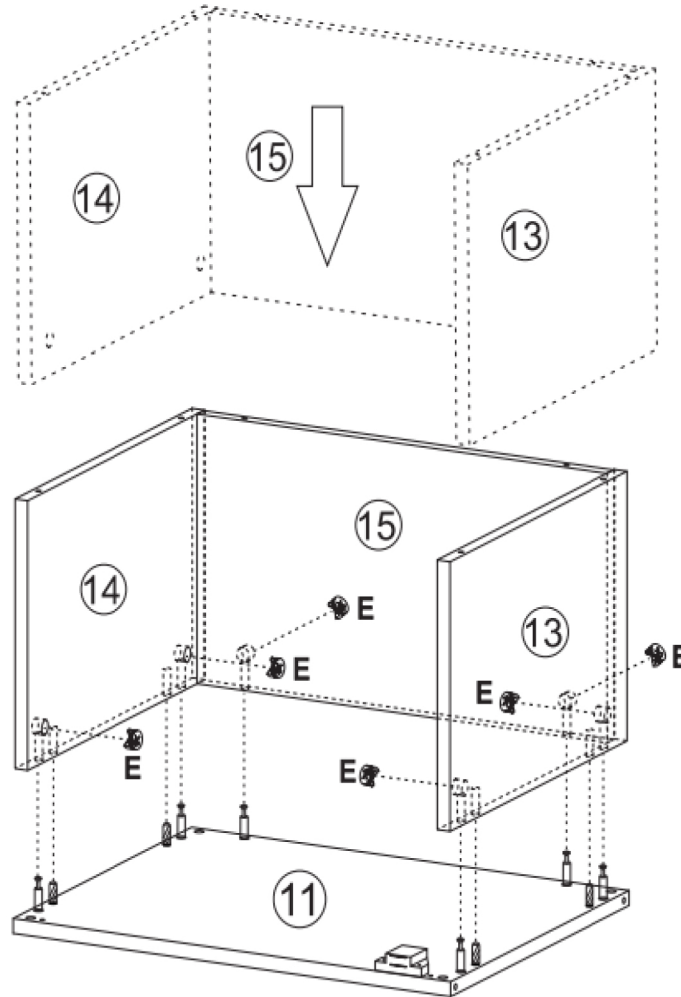

- E x6

Step 3: Turn over the assembled four panels(11,13,14,15) as shown. Insert Shelf Pin(B) into Cabinet Top Panel(11). Then attach Door Panel(16) to Cabinet Top Panel(11), make sure Shelf Pin(B) is inserted into the holes of Door Panel(16). Next, insert Shelf Pin(B) thru Flat Washer(M) into the bottom holes of Door Panel(16), align the holes and attach Cabinet Bottom Panel(12) to the assembled parts, insert six Sharp Bolts(Q) and tighten with supplied Allen Key(A). Do not fully tight all bolts until all parts are in place.

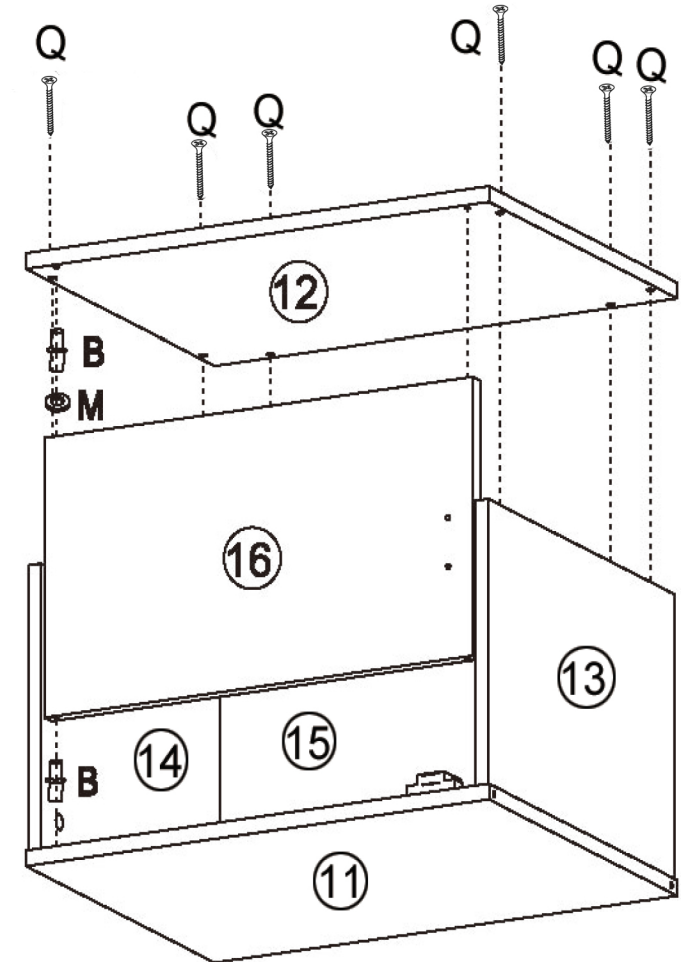

- Q x6
- B x2
- M x1

KITCHEN BAKER'S RACK ASSEMBLY INSTRUCTION

ITEM NO.: KB010101

Step 4: Turn over the assembled parts as shown. Open the doors, attach Door Knob(G) to Door Panel(16), align the holes and insert two Small Bolts(H), fully tighten with supplied Allen Key(A). Attach Mending Plate(O) to Door Panel(16), align the holes and insert two Small Sharp Bolts(P), fully tighten with supplied Allen Key(A). Cabinet assembly is preliminarily completed.

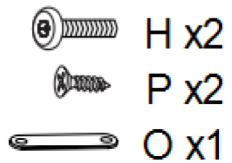
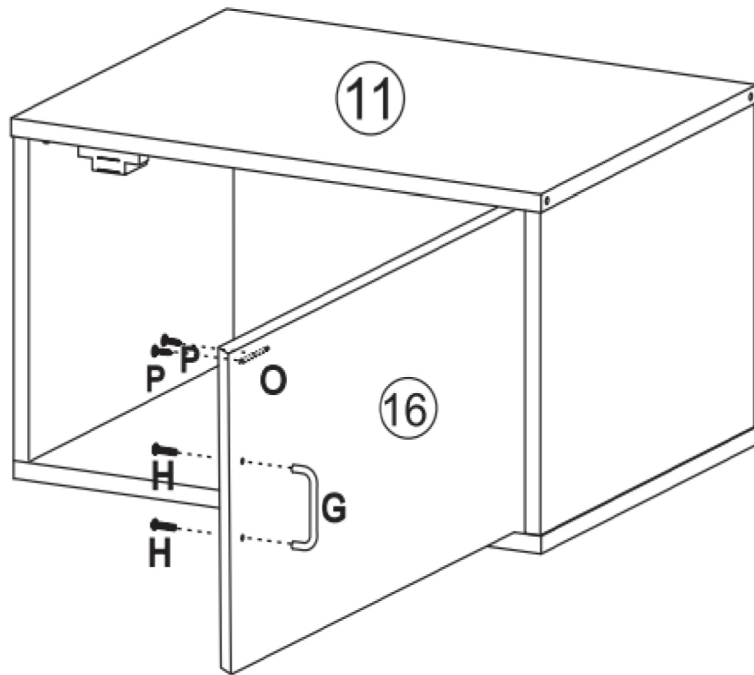

Step 5: With the help of others, attach two Top Crossbars(4) and two Mesh Grids(6) to Left Side Frame(1) and Side Frame(2) as shown, insert twelve Medium Bolts(L) and tighten them with supplied Allen Key(A). Do not fully tight all bolts until all parts are in place.

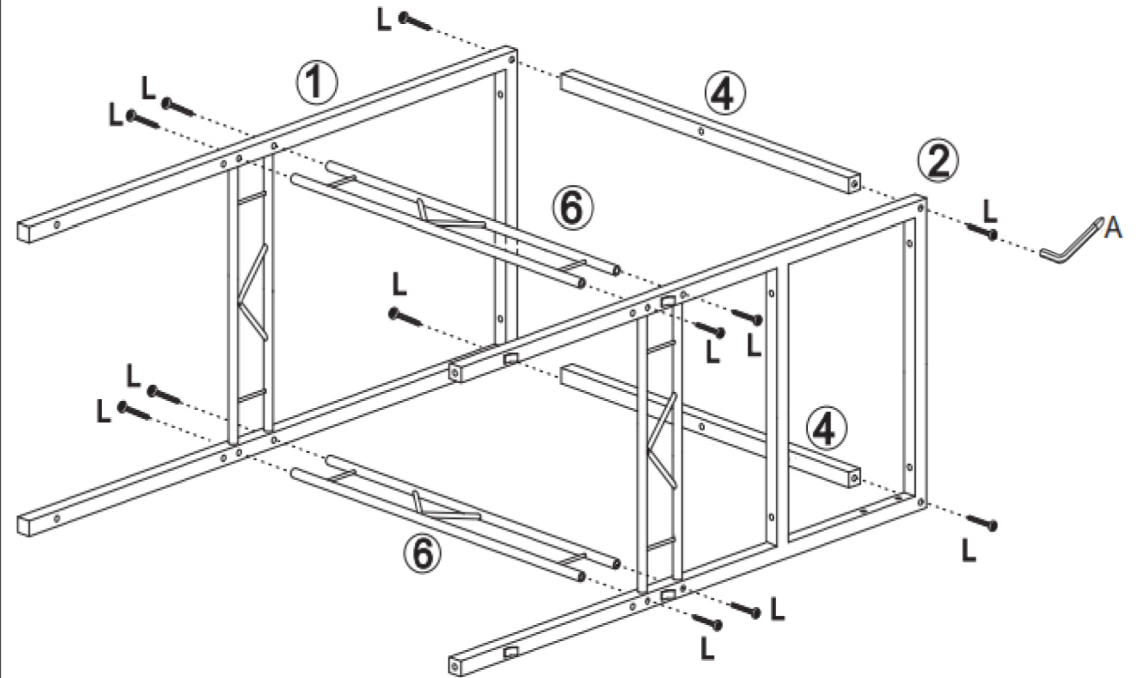

KITCHEN BAKER'S RACK ASSEMBLY INSTRUCTION

ITEM NO.: KB010101

Step 6: Turn over the assembled cabinet as shown, fasten two Bottom Crossbars(7) to Cabinet Bottom Panel(12) by inserting four Bolts(K) and tighten with supplied Allen Key(A). Do not fully tight all bolts until all parts are in place.

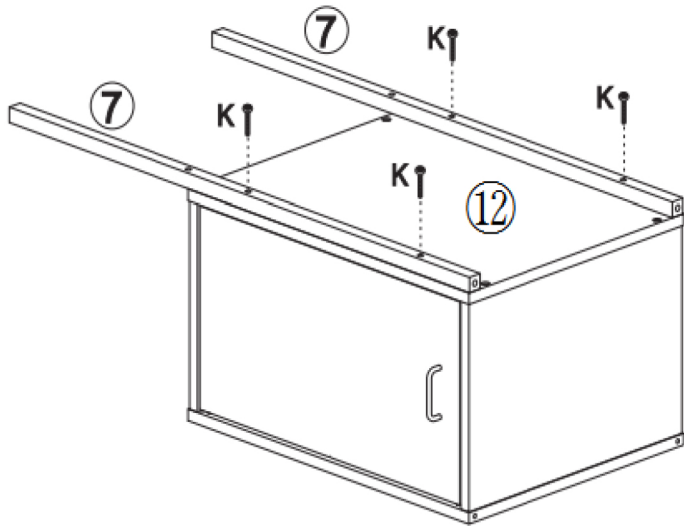

Step 7: Attach the assembled cabinet and Bottom Crossbars(7) to the assembled metal frame from bottom as shown, align the holes and insert four Medium Bolts(L) and four Long Sharp Bolts(F), tighten them with supplied Allen Key(A). Do not fully tight all bolts until all parts are in place.

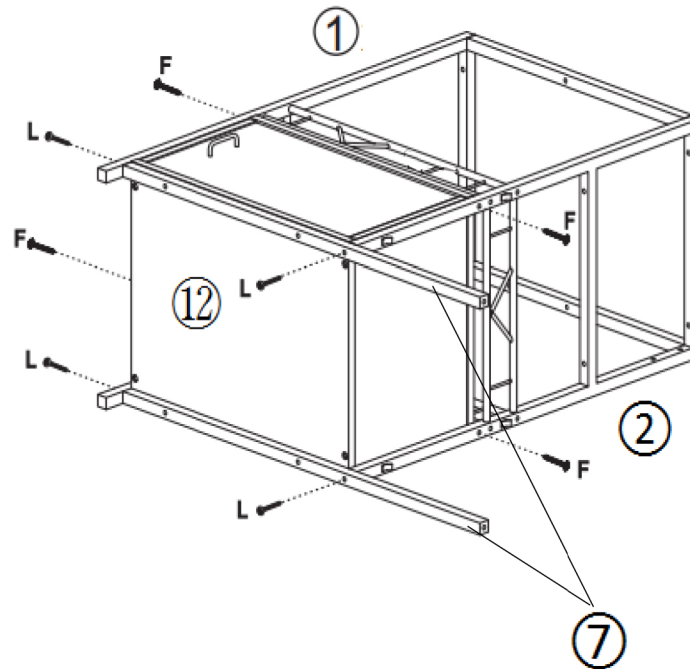

Step 8: Attach Right Side Frame(3) to two Bottom Crossbars(7) as shown, insert two Medium Bolts(L) from side and tighten with supplied Allen Key(A). Do not fully tight all bolts until all parts are in place.

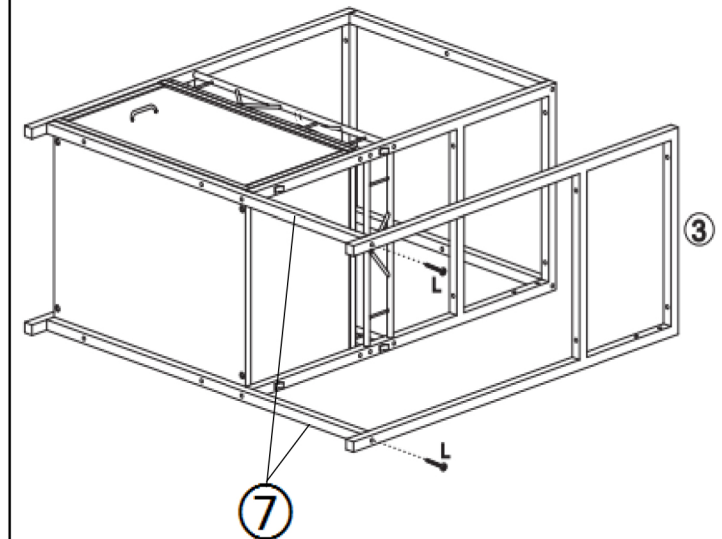

KITCHEN BAKER'S RACK ASSEMBLY INSTRUCTION

ITEM NO.: KB010101

Step 9: With the help of others, flip on the assembled part gently to make it stand. Attach Shelf Panel(10) to Side Frame(2) and Right Side Frame(3) as shown, insert four Bolts(K) and tighten them with supplied Allen Key(Q). Then attach Top Panel(9) to Left Side Frame(1), Side Frame(2) and Right Side Frame(3), insert eight Bolts(K) and tighten them with supplied Allen Key(A). Do not fully tight all bolts until all parts are in place.

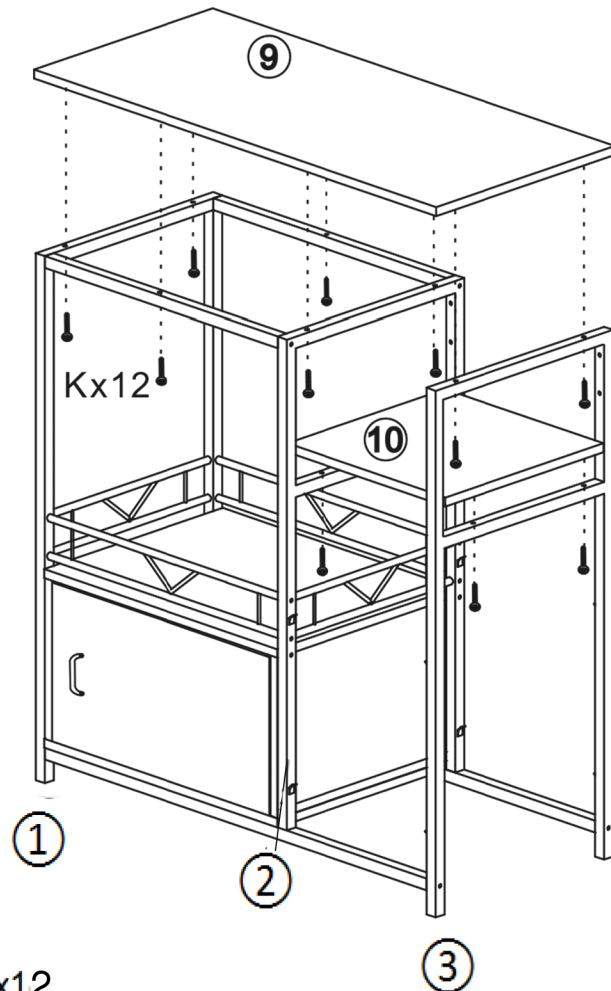

Step 10: Fasten two Support Bars(5) to Side Frame(2) and Right Side Frame(3) by inserting four Long Bolts(I) and four Nuts(J), tighten them with supplied Allen Key(A). Attach Top Rack(8) to two Support Bars(5) as shown, align the holes and insert four Long Sharp Bolts(F), tighten with supplied Allen Key(A). Hook Top and Bottom Basket(17)(18) to Side Frame(2) and Right Side Frame(3) as shown. Fully re-tighten all bolts and assembly is completed.

